

**Local Call - Intraswitch  
CLEC A Originating to CLEC B Terminating:**

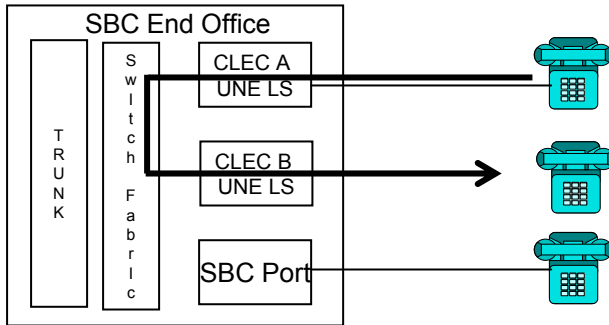

**Neither CLEC A or CLEC B bills SBC any charges**

**SBC may bill CLEC A**

Switch Usage - Intraoffice  
- Set-up per completed call  
- Holding term per MOU

**SBC West sends CLEC A**

- Category 10 Record  
(module 18 attached)

**Notice**

These illustrative call flow scenarios and the information contained in them are subject to change at any time without notice, including as a result of regulatory decisions, arbitration awards, and subsequent interconnection agreements. Also, to the extent that a CLEC's interconnection agreement is contrary to this information, the agreement shall control.

Call flows for ULS-ST  
Based on 13-State Generic ICA

**Local Call - Intraswitch  
CLEC A Originating to SBC (or CLEC Resale) Terminating**

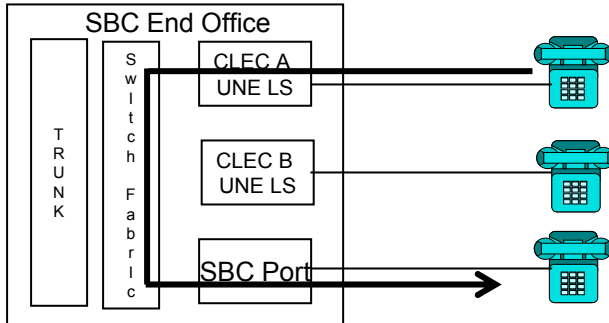

**CLEC A does not bill SBC any charges**

**SBC may bill CLEC A**

Switch Usage - Intraoffice  
- Set-up per completed call  
- Holding term per MOU

**SBC West sends CLEC A**

- Category 10 Record  
(module 18 attached)

**Notice**

These illustrative call flow scenarios and the information contained in them are subject to change at any time without notice, including as a result of regulatory decisions, arbitration awards, and subsequent interconnection agreements. Also, to the extent that a CLEC's interconnection agreement is contrary to this information, the agreement shall control.

Call flows for ULS-ST  
Based on 13-State Generic ICA

# Local Call - Intraswitch SBC Originating to CLEC A Terminating

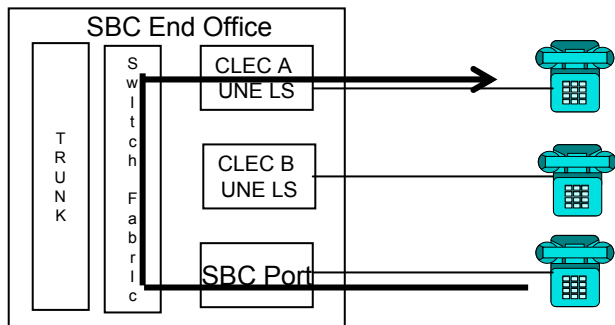

**CLEC A and SBC do not bill any charges to each other**

### Notice

These illustrative call flow scenarios and the information contained in them are subject to change at any time without notice, including as a result of regulatory decisions, arbitration awards, and subsequent interconnection agreements. Also, to the extent that a CLEC's interconnection agreement is contrary to this information, the agreement shall control.

Call flows for ULS-ST  
Based on 13-State Generic ICA

**Local Calls - Interswitch  
CLEC A Originating to SBC (or Resale) Terminating**

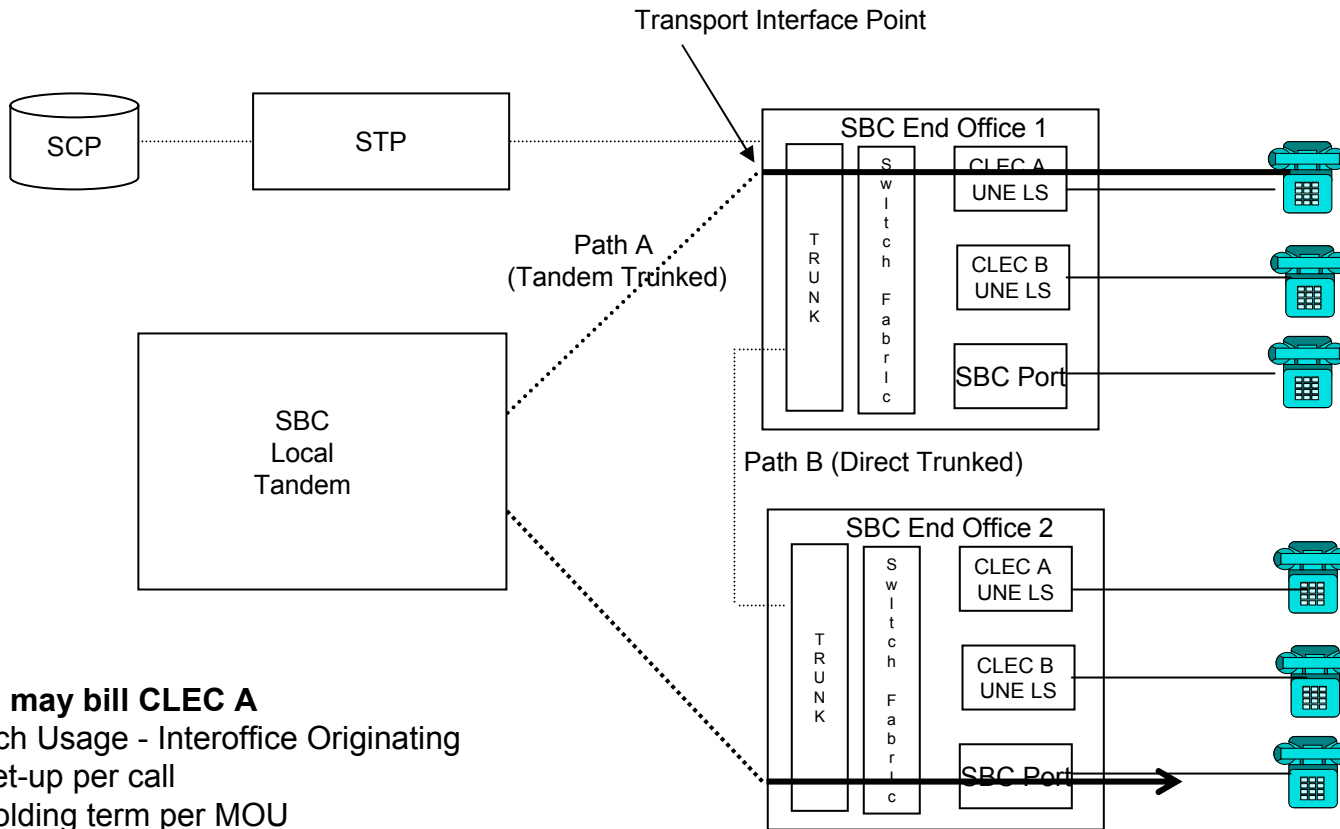

**SBC may bill CLEC A**

Switch Usage - Interoffice Originating

Set-up per call

Holding term per MOU

Shared Transport

Fixed Mileage per MOU

Variable Mileage per MOU per Mile

**SBC West sends CLEC A**

- Cat 10 Record

**SBC West may bill CLEC A Recip Comp**

**Notice**

These illustrative call flow scenarios and the information contained in them are subject to change at any time without notice, including as a result of regulatory decisions, arbitration awards, and subsequent interconnection agreements. Also, to the extent that a CLEC's interconnection agreement is contrary to this information, the agreement shall control.

Call flows for ULS-ST  
Based on 13-State Generic ICA

**Local Calls - Interswitch  
CLEC A Originating to CLEC C (FBN) Terminating**

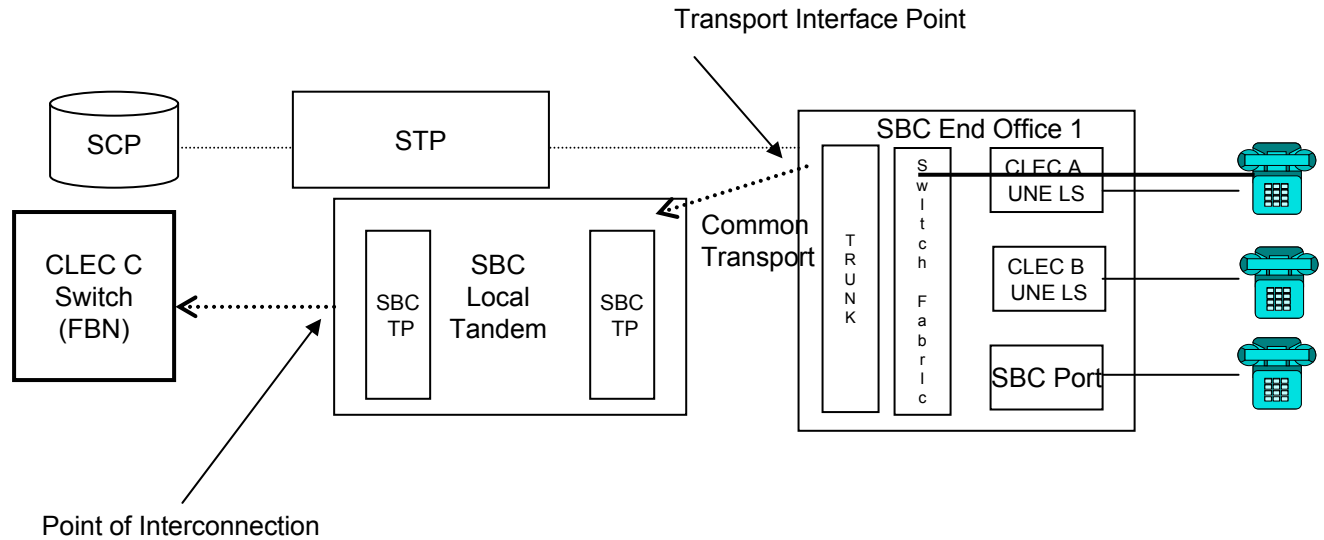

**SBC may bill CLEC A**

Switch Usage - Interoffice Originating

Set-up per call

Holding term per MOU

Common Transport

Fixed Mileage per MOU

Variable Mileage per MOU per Mile

Tandem Switching

Set-up per completed call

Holding term per MOU

**SBC West sends CLEC A**

- Cat 10 EMR Record  
(Module 18A with OCN attached)

**SBC West sends CLEC B**

- Category 50 record with originating party OCN attached

CLEC C may deal directly with CLEC A for terminating comp

**Notice**

These illustrative call flow scenarios and the information contained in them are subject to change at any time without notice, including as a result of regulatory decisions, arbitration awards, and subsequent interconnection agreements. Also, to the extent that a CLEC's interconnection agreement is contrary to this information, the agreement shall control.

Call flows for ULS-ST  
Based on 13-State Generic ICA

**Local Calls - Interswitch  
SBC (or CLEC Resale) Originating to CLEC A Terminating**

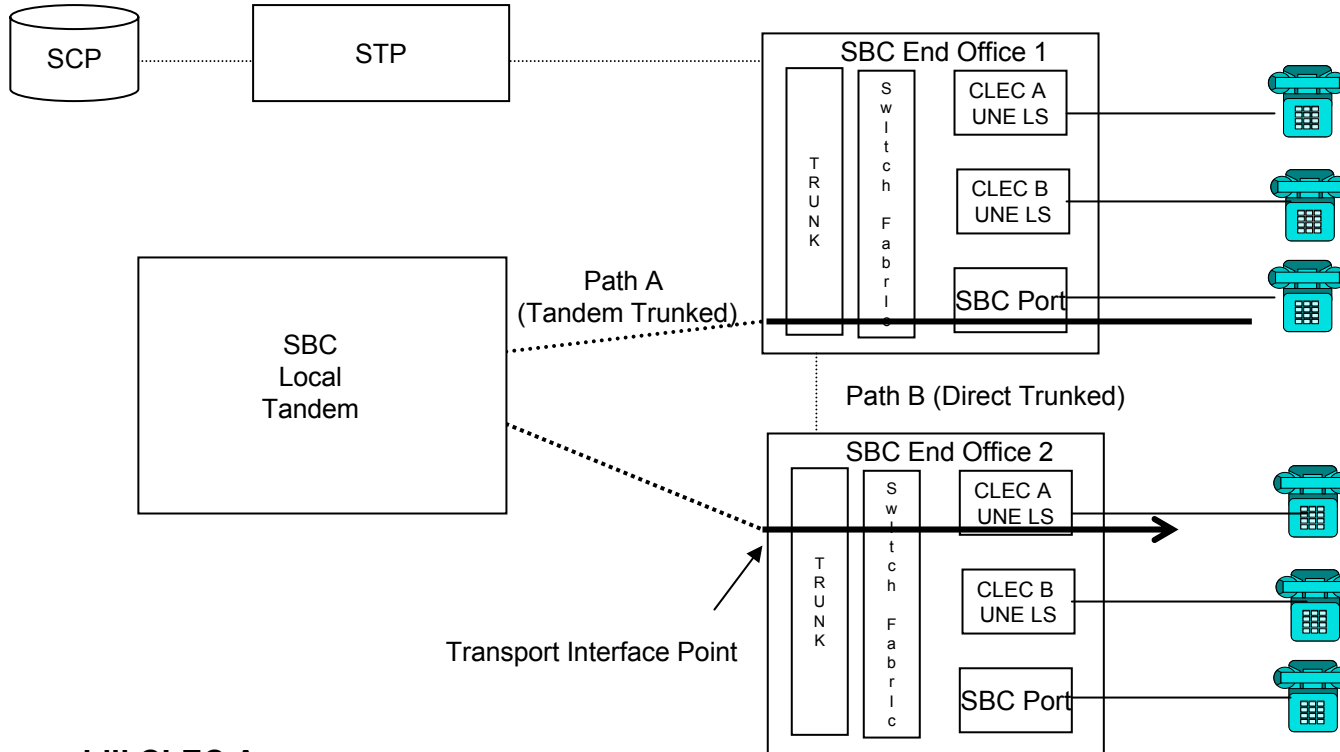

**SBC may bill CLEC A**

No record available for billing (no charges apply)

**SBC West sends CLEC A**

No record available for billing or exchange  
SBC agrees not to charge terminating switching in return for CLEC's agreement not to charge SBC recip comp

**Notice**

These illustrative call flow scenarios and the information contained in them are subject to change at any time without notice, including as a result of regulatory decisions, arbitration awards, and subsequent interconnection agreements. Also, to the extent that a CLEC's interconnection agreement is contrary to this information, the agreement shall control.

Call flows for ULS-ST  
Based on 13-State Generic ICA

**Local Calls - Interswitch  
CLEC C (FBN) Originating to CLEC A Terminating**

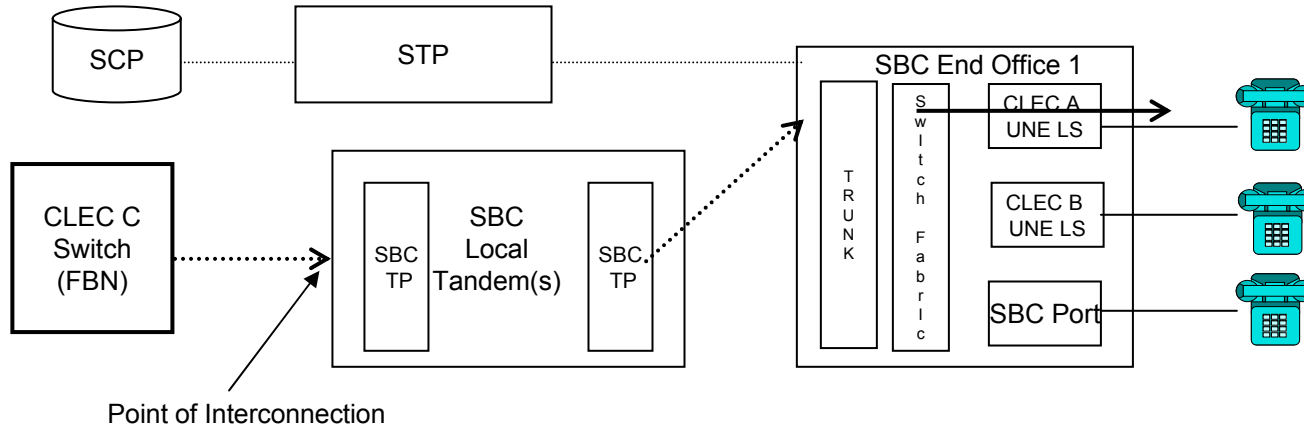

**SBC may bill CLEC A**

- Switch Usage - Interoffice Terminating
  - Set-up per call
  - Holding term per MOU
- Common Transport
  - Fixed Mileage per MOU
  - Variable Mileage per MOU per Mile
- Tandem Switching
  - Set-up per completed call
  - Holding term per MOU

**SBC West sends CLEC A**

- Category 11 record with originating party OCN attached

CLEC A may deal directly with CLEC C for terminating comp; SBC not responsible for any charges by CLEC A

**Notice**

These illustrative call flow scenarios and the information contained in them are subject to change at any time without notice, including as a result of regulatory decisions, arbitration awards, and subsequent interconnection agreements. Also, to the extent that a CLEC's interconnection agreement is contrary to this information, the agreement shall control.

Call flows for ULS-ST  
Based on 13-State Generic ICA

**Toll Calls - - Intrastate / InterLATA / IntraLATA  
CLEC A Originating to IXC**

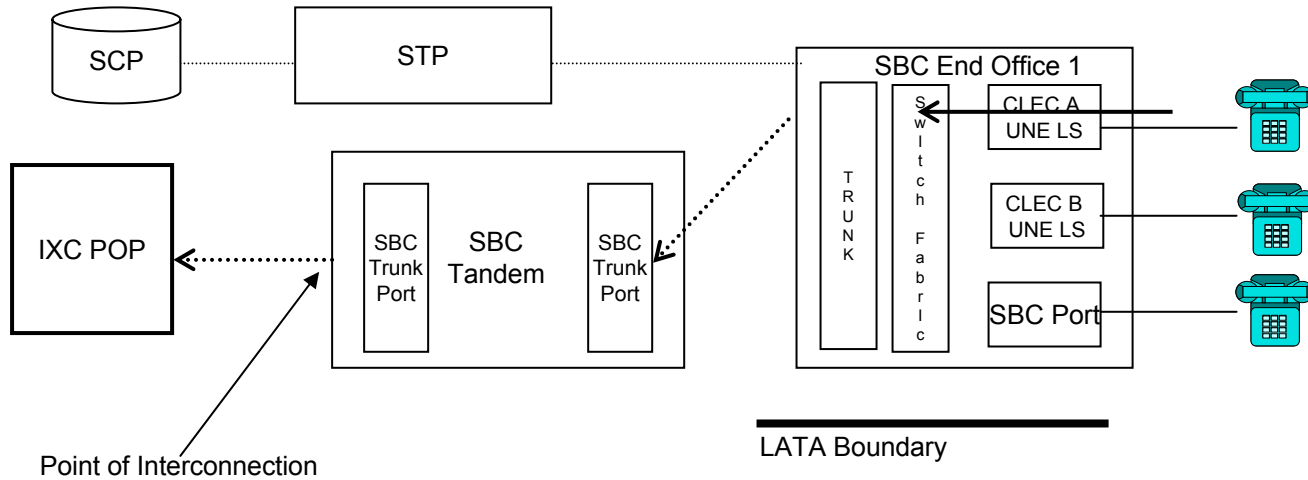

**SBC may bill CLEC A**

Switch Usage - Interoffice Originating

Set-up per call

Holding term per MOU

Common Transport\*

Fixed Mileage per MOU

Variable Mileage per MOU per Mile

Tandem Switching\*

Set-up per completed call

Holding term per MOU

**SBC West sends CLEC A**

- Category 11 access record

\*These charges will not apply when the IXC elects to interconnect traffic via Direct End Office arrangements at SBC End Office

1

**Notice**

These illustrative call flow scenarios and the information contained in them are subject to change at any time without notice, including as a result of regulatory decisions, arbitration awards, and subsequent interconnection agreements. Also, to the extent that a CLEC's interconnection agreement is contrary to this information, the agreement shall control.

Call flows for ULS-ST  
Based on 13-State Generic ICA



**Toll Calls - - Intrastate / Interstate/ InterLATA / IntraLATA  
IXC to CLEC A**

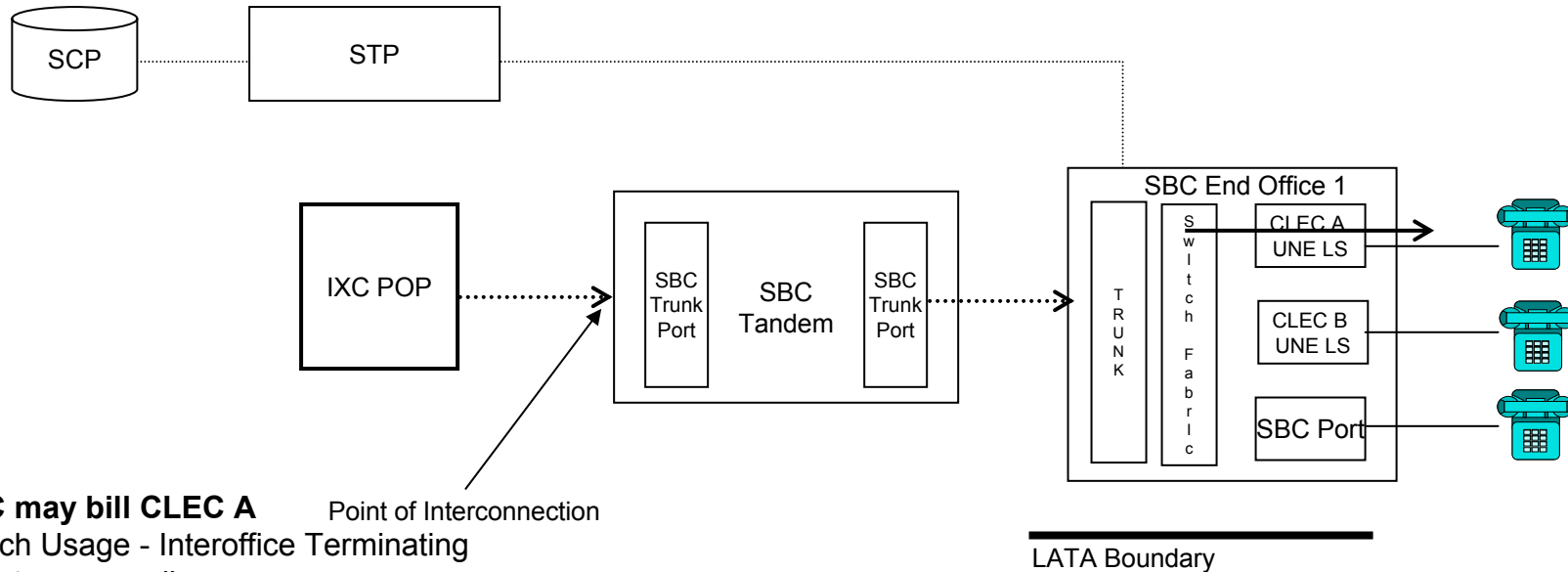

**SBC may bill CLEC A** Point of Interconnection

Switch Usage - Interoffice Terminating

Set-up per call

Holding term per MOU

Common Transport\*

Fixed Mileage per MOU

Variable Mileage per MOU per Mile

Tandem Switching\*

Set-up per completed call

Holding term per MOU

**SBC West sends CLEC A**

- Category 11 access record

\* These charges will not apply when the IXC elects to interconnect traffic via Direct End Office arrangements at SBC End Office 1

**Notice**

These illustrative call flow scenarios and the information contained in them are subject to change at any time without notice, including as a result of regulatory decisions, arbitration awards, and subsequent interconnection agreements. Also, to the extent that a CLEC's interconnection agreement is contrary to this information, the agreement shall control.

Call flows for ULS-ST  
Based on 13-State Generic ICA

**Local Calls - Interswitch  
CLEC A Originating to CLEC A (or B) Terminating**

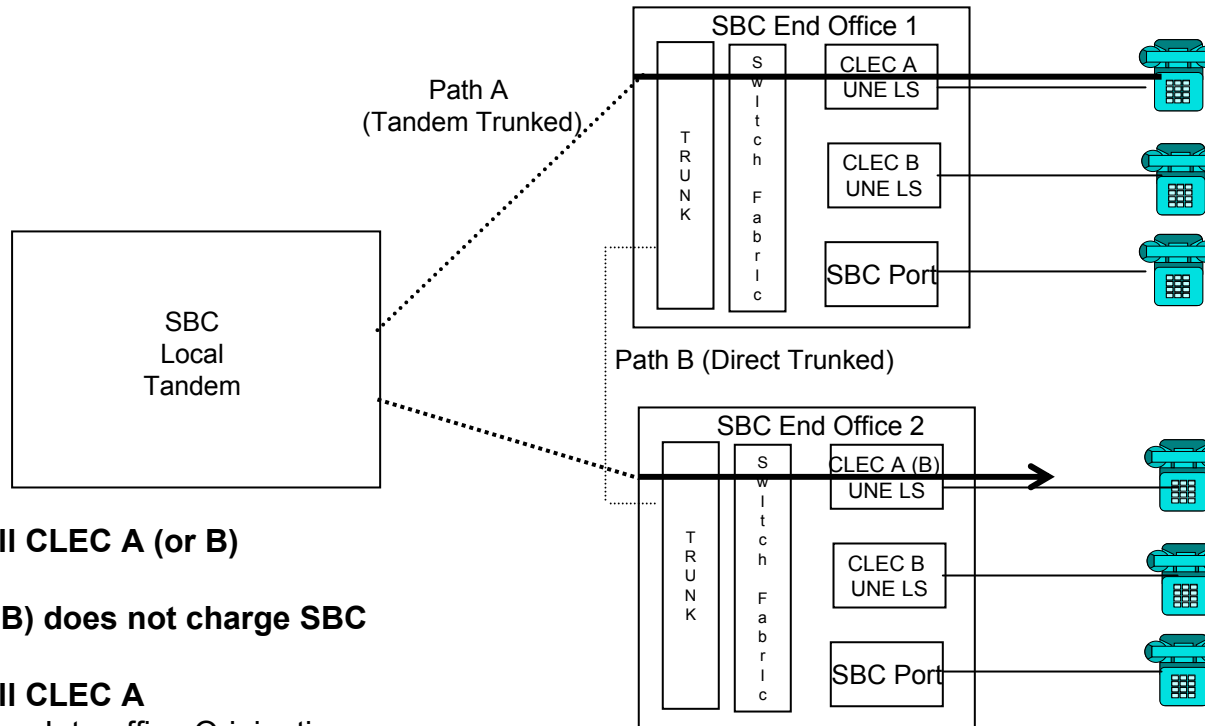

**SBC may bill CLEC A (or B)**

**CLEC A (or B) does not charge SBC**

**SBC may bill CLEC A**

Switch Usage - Interoffice Originating

Set-up per call

Holding term per MOU

Shared Transport

Fixed Mileage per MOU

Variable Mileage per MOU per Mile

**SBC may bill CLEC A (or B)**

Switch Usage - Interoffice Terminating

Set-up per call

Holding term per MOU

CLECs may deal with each other for compensation for terminating call

**SBC sends CLEC A (or B)**

Originating CLEC - Cat 10 record

Terminating CLEC - Cat 11 record

**Notice**

These illustrative call flow scenarios and the information contained in them are subject to change at any time without notice, including as a result of regulatory decisions, arbitration awards, and subsequent interconnection agreements. Also, to the extent that a CLEC's interconnection agreement is contrary to this information, the agreement shall control.

Call flows for ULS-ST  
Based on 13-State Generic ICA

**IntraLATA Toll Calls - Over SBC IntraLATA Interexchange Facilities Only (utilizing AT&T's Option C)  
CLEC A Originating to SBC Terminating**

**UNE-P Call Scenario 11**

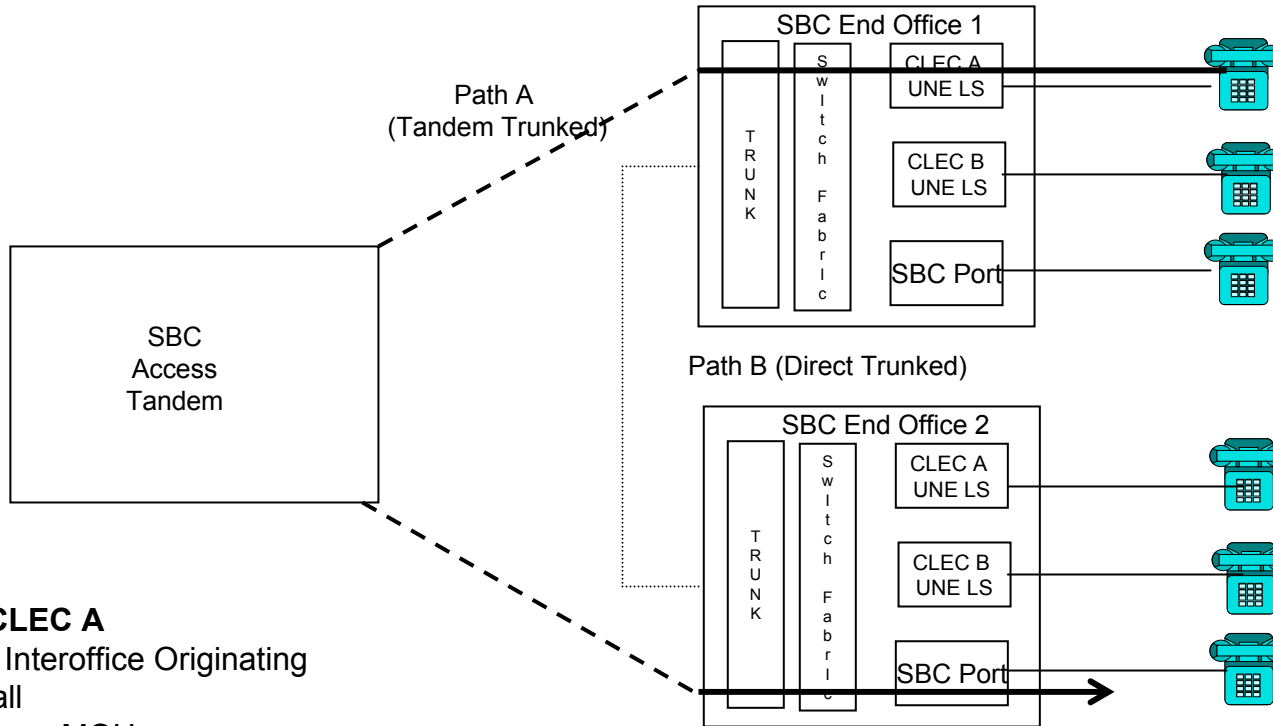

**SBC may bill CLEC A**

- Switch Usage - Interoffice Originating
  - Set-up per call
  - Holding term per MOU
- Shared Transport
  - Fixed Mileage per MOU
  - Variable Mileage per MOU per Mile

**Terminating Switch Access**

- Set-up per call
- Holding term per MOU

**SBC sends CLEC A**

Cat 10 record

**Notice**

These illustrative call flow scenarios and the information contained in them are subject to change at any time without notice, including as a result of regulatory decisions, arbitration awards, and subsequent interconnection agreements. Also, to the extent that a CLEC's interconnection agreement is contrary to this information, the agreement shall control.

Call flows for ULS-ST  
Based on 13-State Generic ICA

**Toll Calls- Interswitch**  
**CLEC A Originating to tandem to I-Tandem to ILEC**

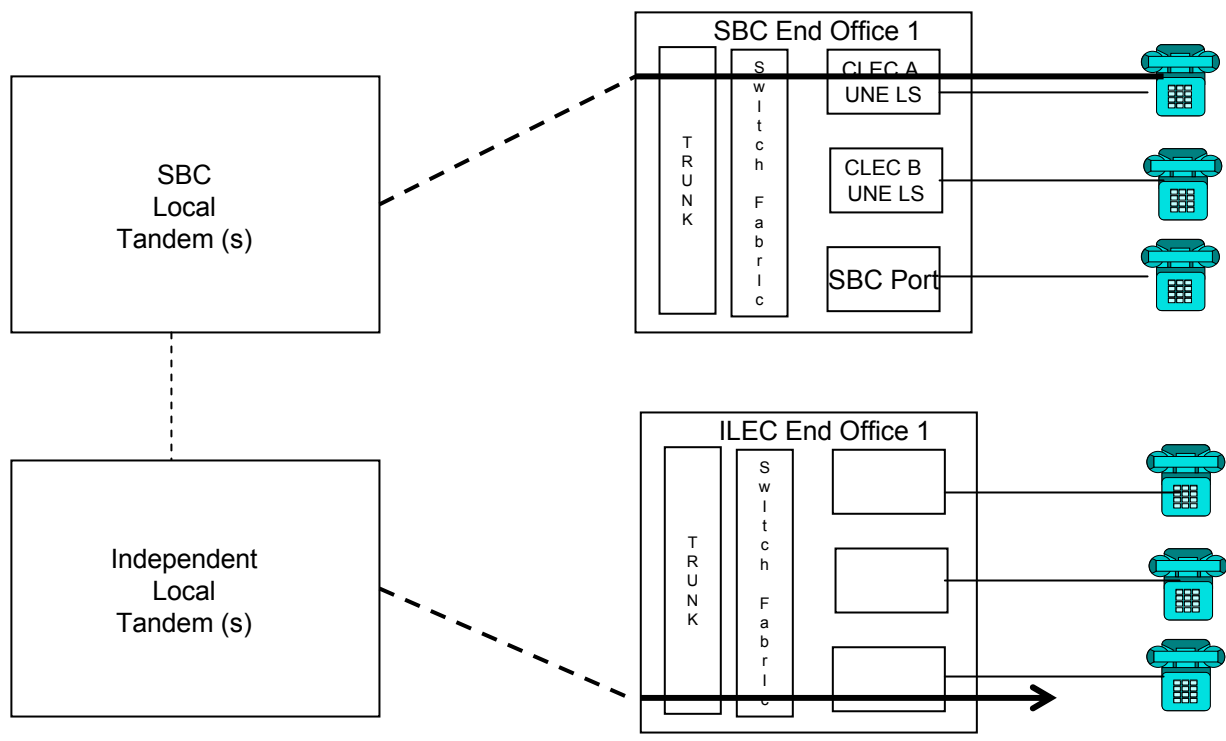

- SBC may bill CLEC A**
- Switch Usage - Interoffice Originating
    - Set-up per call
    - Holding term per MOU
  - Common Transport
    - Fixed Mileage per MOU
    - Variable Mileage per MOU per Mile
  - Tandem Switching
    - Set-up per completed call
    - Holding term per MOU

- SBC sends CLEC A**  
CAT 10 record
- SBC sends ILEC**  
CAT 50 record with (originating party OCN attached)
- SBC will pass any ILEC charges to CLEC A**

**Notice**

These illustrative call flow scenarios and the information contained in them are subject to change at any time without notice, including as a result of regulatory decisions, arbitration awards, and subsequent interconnection agreements. Also, to the extent that a CLEC's interconnection agreement is contrary to this information, the agreement shall control.

Call flows for ULS-ST  
 Based on 13-State Generic ICA

**IntraLATA Toll Calls - Over SBC IntraLATA Interexchange Facilities Only (utilizing AT&T's Option C)**

**Toll Calls - Interswitch  
CLEC A Originating to CLEC B Terminating**

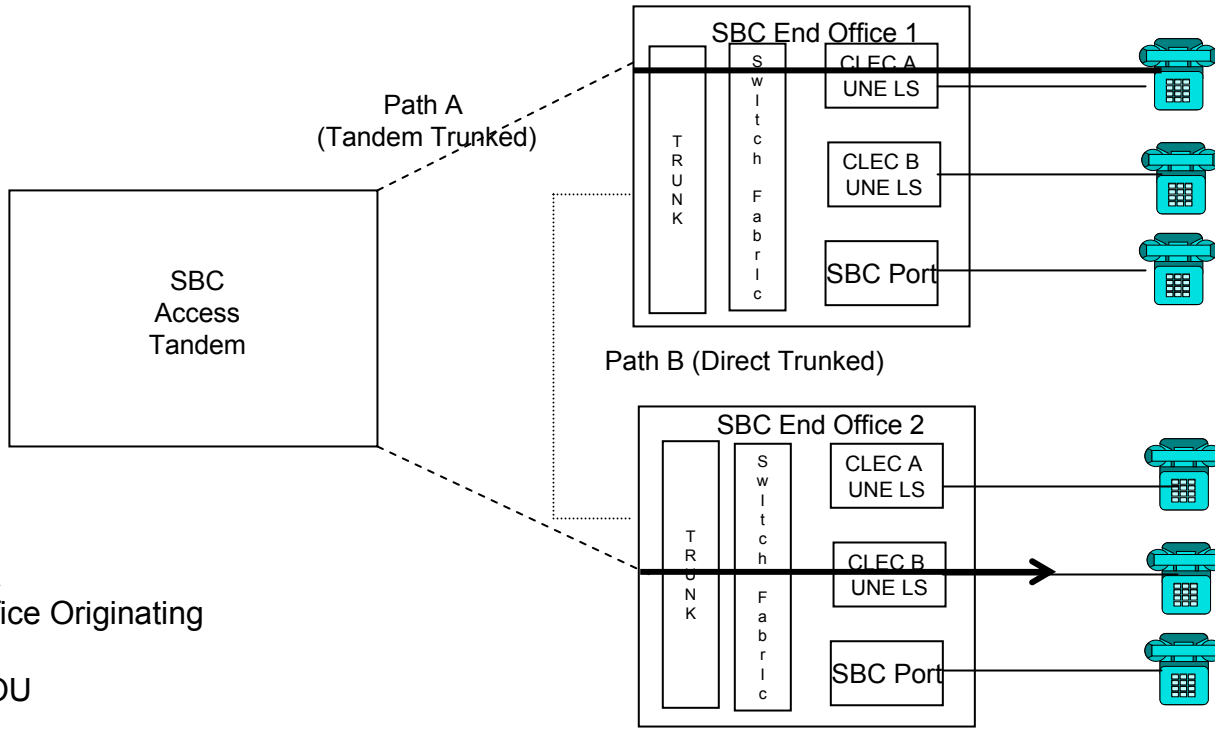

**SBC may bill CLEC A**  
 Switch Usage - Interoffice Originating  
 Set-up per call  
 Holding term per MOU  
 Shared Transport  
 Fixed Mileage per MOU  
 Variable Mileage per MOU per Mile

**SBC may bill CLEC B**  
 Switch Usage - Interoffice Terminating  
 Set-up per call  
 Holding term per MOU

**CLEC A and B may deal with each other for completion of terminating call  
 SBC passes any CLEC B charges back to CLEC A**

**SBC sends CLEC A**  
 CAT 10 record with (originating party OCN attached)

**SBC sends CLEC B**  
 CAT 11 record

**Notice**

These illustrative call flow scenarios and the information contained in them are subject to change at any time without notice, including as a result of regulatory decisions, arbitration awards, and subsequent interconnection agreements. Also, to the extent that a CLEC's interconnection agreement is contrary to this information, the agreement shall control.

Call flows for ULS-ST  
 Based on 13-State Generic ICA